

YS640S BUILT-IN PELLET COOKER

NOTCH MOUNT INSTALLATION

Overall Height: **35.7 in.** Overall Depth: **20.9 in.** Overall Length: **52.2 in.** Total Weight: **291 lbs.**

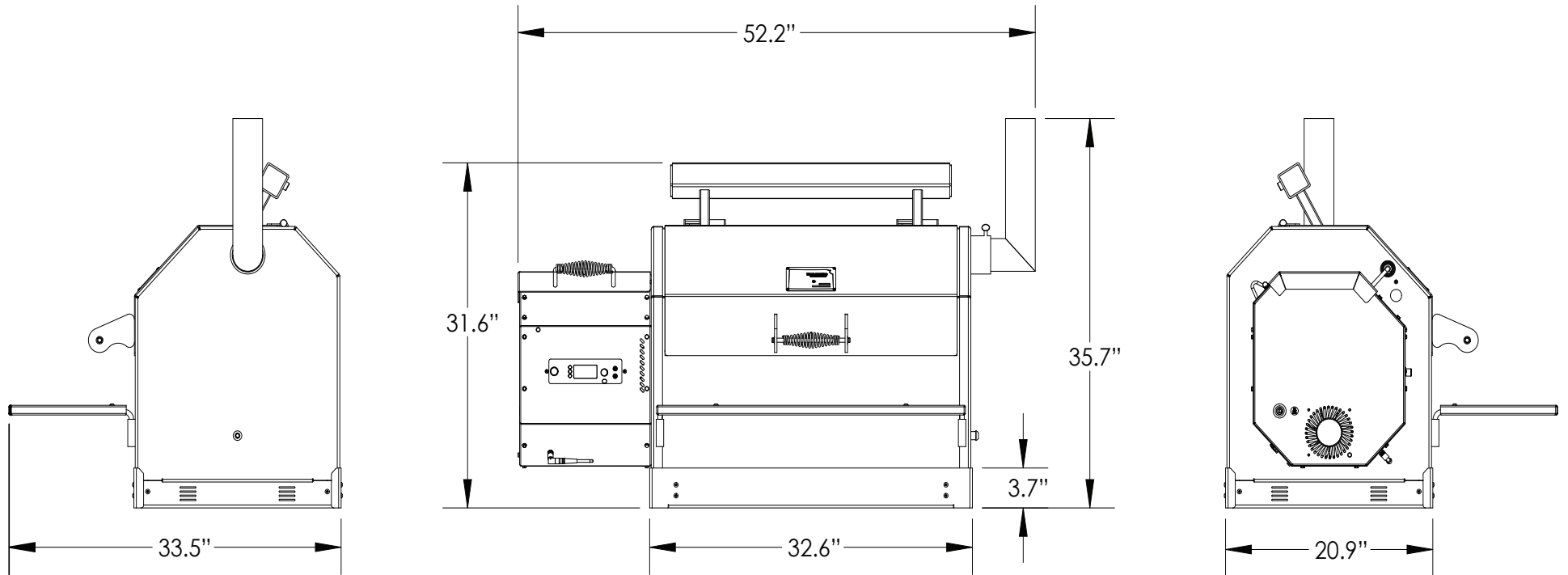

YS640S BUILT-IN PELLET COOKER

NOTCH MOUNT CUTOUT DIMENSIONS

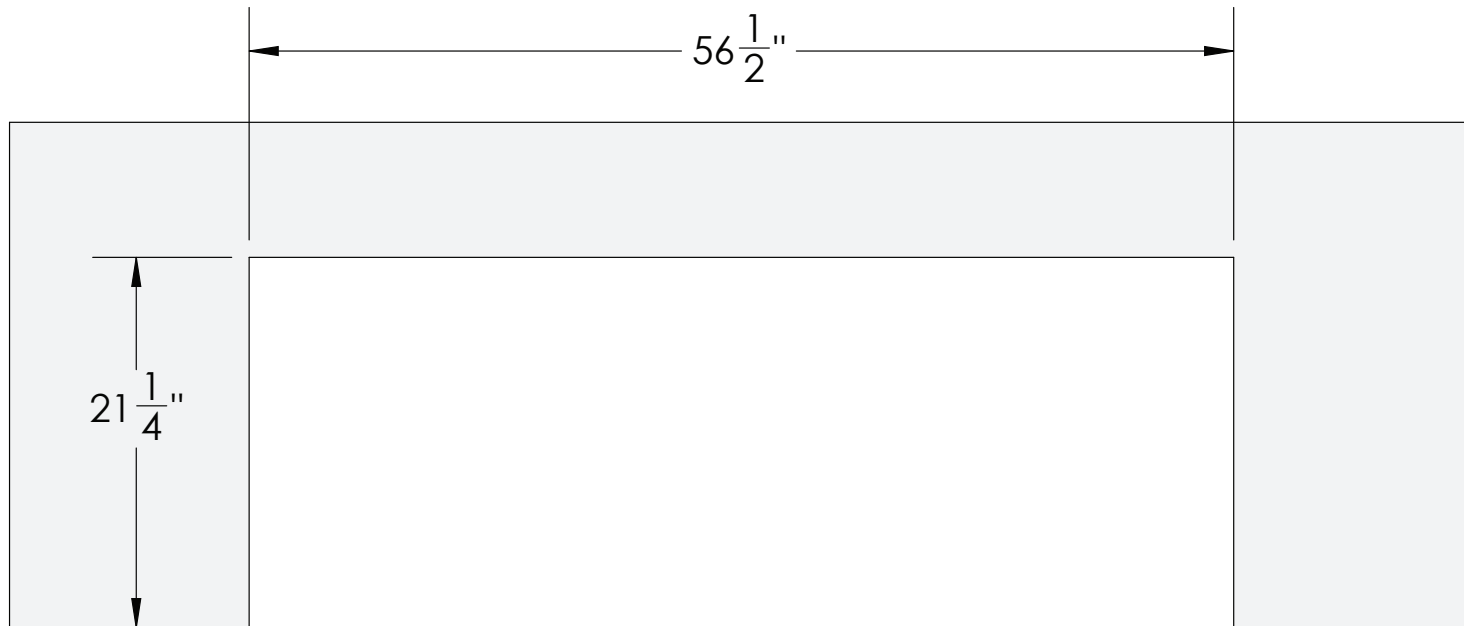

NOTE: STRUCTURE MUST BE ABLE TO SUPPORT AT LEAST 350 LBS

YS640S BUILT-IN PELLET COOKER

NOTCH MOUNT HOLE PATTERN

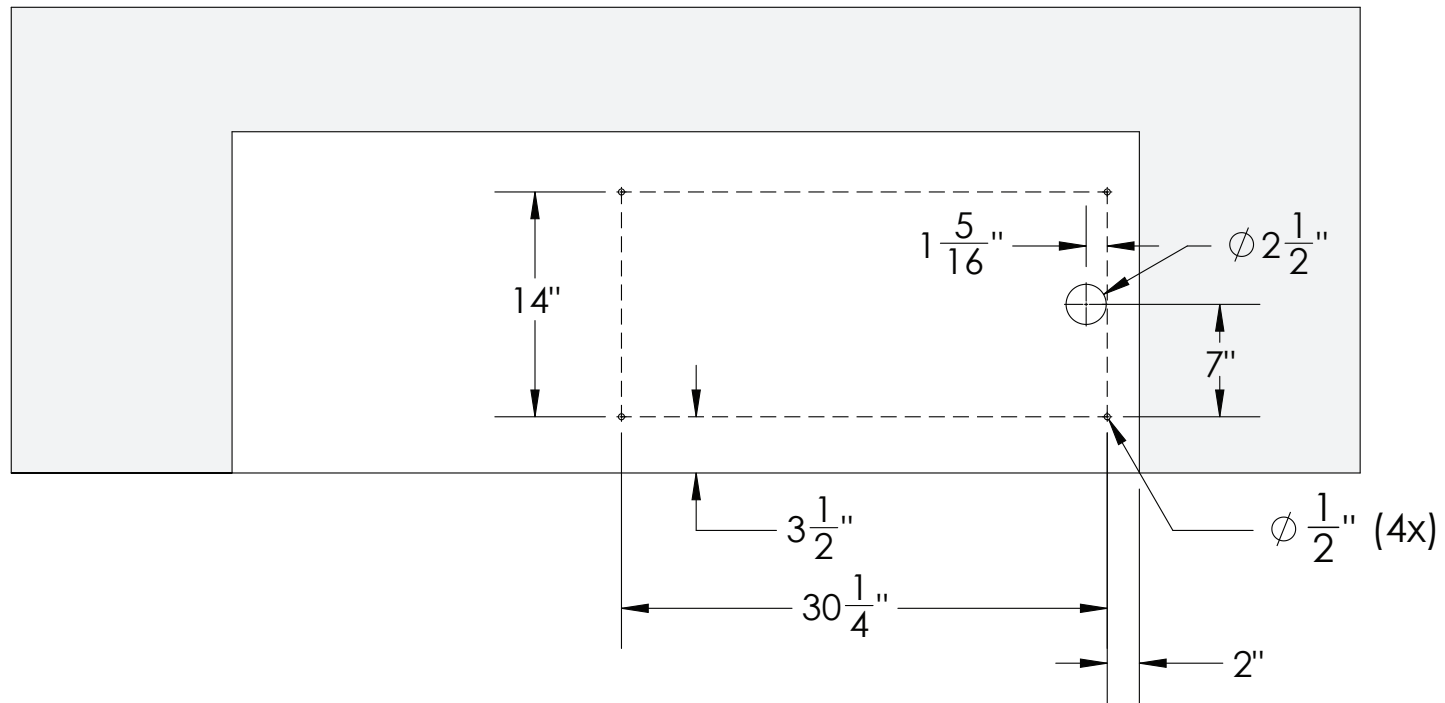

NOTE: STRUCTURE MUST BE ABLE TO SUPPORT AT LEAST 350 LBS

YS640S BUILT-IN PELLET COOKER

NOTCH MOUNT INSTALL REFERENCE

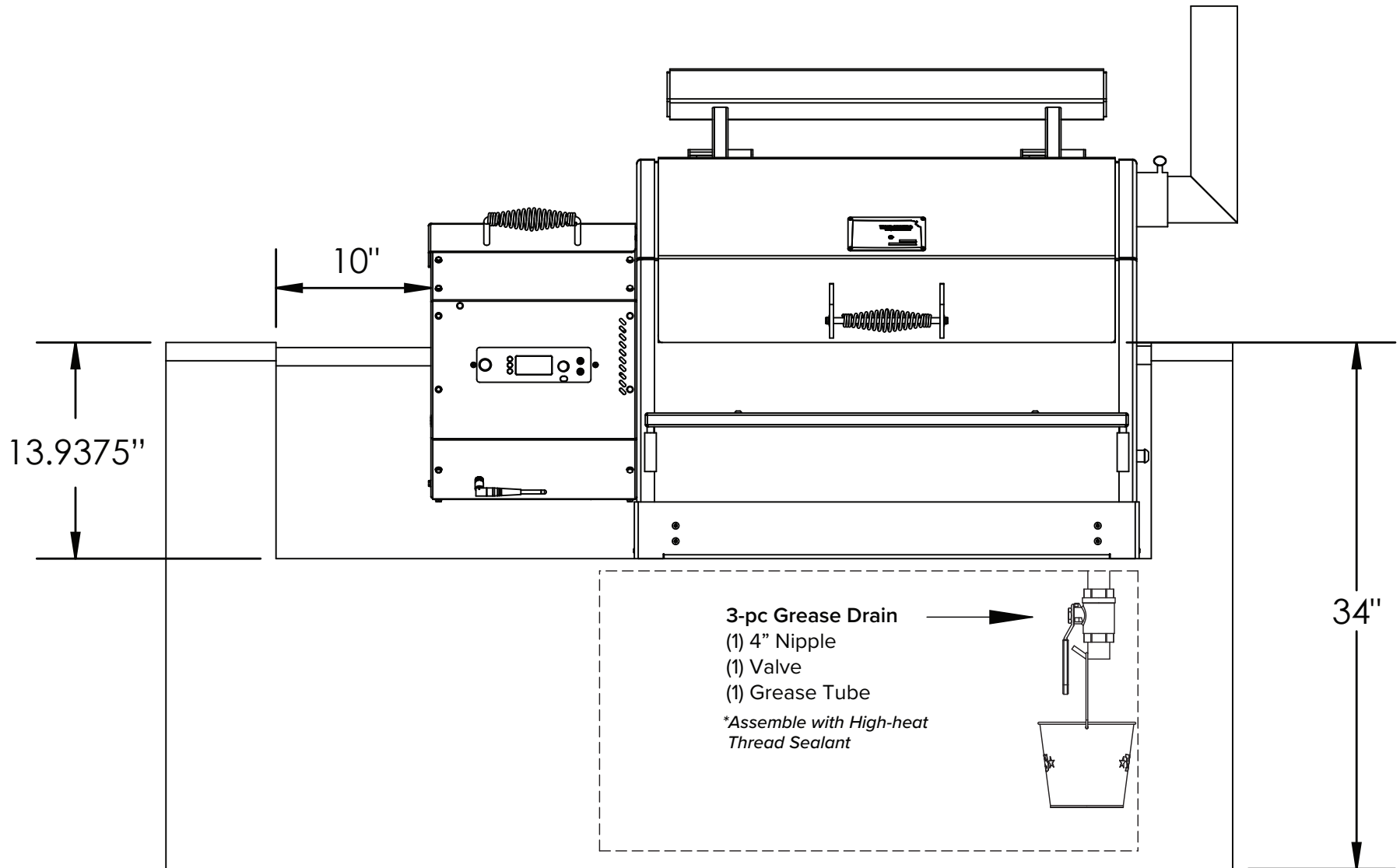

YS640S BUILT-IN PELLET COOKER

RECOMMENDED CLEARANCES

