



EL DORADO 42"

OPERATION MANUAL

★ **YODER SMOKERS** ★

PREMIUM GRILLS & SMOKERS

★ YODER SMOKERS ★
PREMIUM GRILLS & SMOKERS

CONTENTS

Dangers, Warnings & Cautions.....6

Operating Your Grill8

Initial Burn-in10

Cooking on the Grill11

Routine Maintenance12

FAQs13

Components & Parts14-25

Warranty.....26

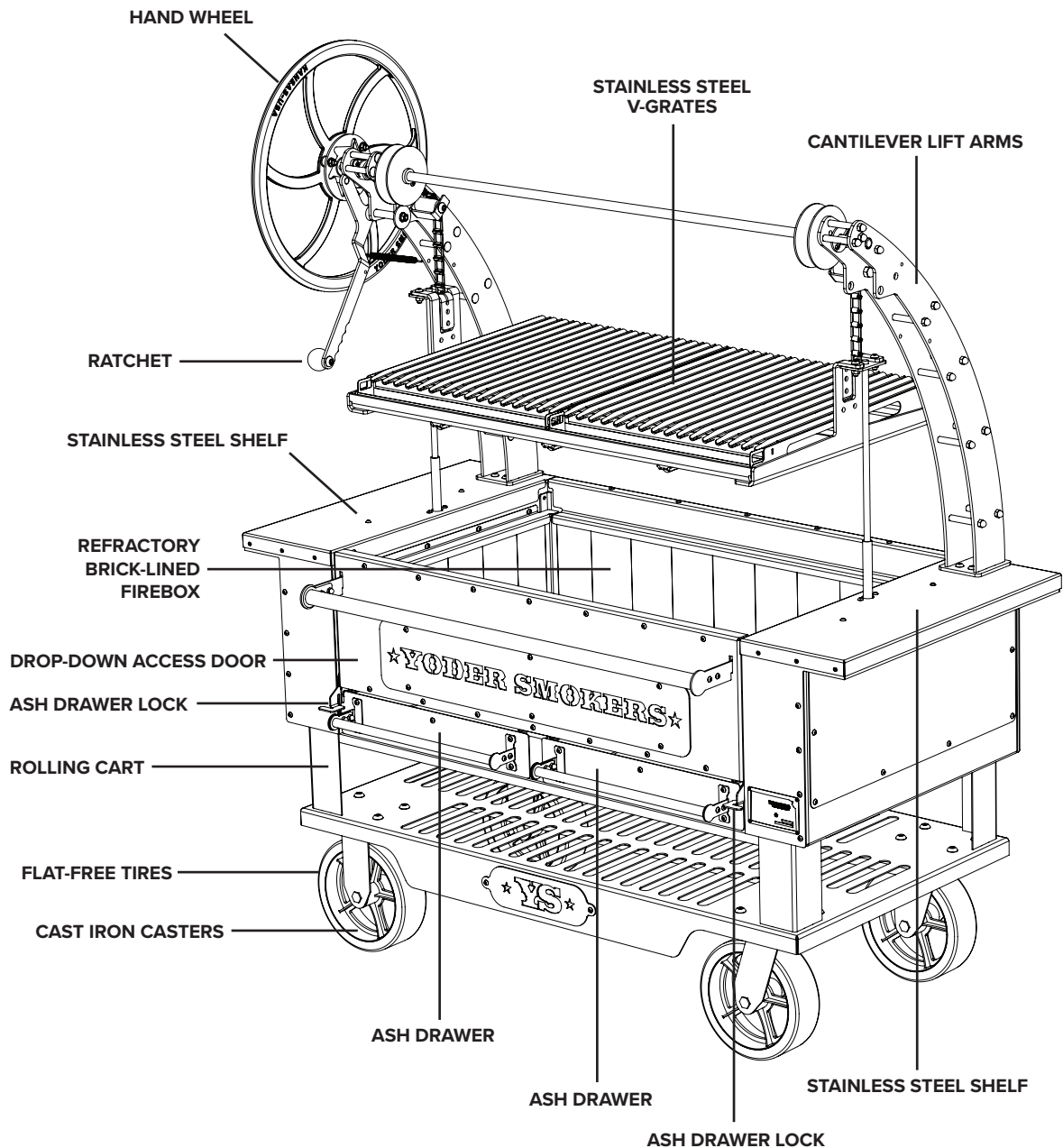



DANGERS, WARNINGS, AND CAUTIONS



PLEASE READ THIS ENTIRE MANUAL BEFORE USING YOUR NEW YODER SMOKERS CHARCOAL GRILL.

Failure to follow the instructions in this manual could result in property damage, bodily injury, or even death. Contact your local fire officials about restrictions and installation inspection requirements in your area if you have questions on the positioning of your grill. As with any grill, toxic gases such as carbon monoxide are formed. Harmful in concentrated quantities, carbon monoxide is odorless and can lead to death. ONLY USE THIS GRILL in an outdoor, open-air environment where the carbon monoxide can naturally dissipate.



DANGER!

Do not use indoors. This grill is designed for outdoor use in a well-ventilated area and is not intended for and should never be operated as a heat source. If used indoors, odorless carbon monoxide fumes can accumulate and cause bodily harm including asphyxiation and even death.

Do not use in a garage, building, tent, breezeway, or any other enclosed area.

Do not use gasoline, kerosene, alcohol, or other highly volatile fluids to ignite charcoal.

Do not operate the grill near flammable vapors or liquids and keep clear of any combustible materials.

Do not remove any ash until all charcoal is completely burned out and fully extinguished and grill is cool.

Do not dump hot charcoal where it might be stepped on or be a fire hazard. Never dump ashes or charcoal before they are fully extinguished.

Do not store the grill until ashes and charcoal are fully extinguished and the grill is completely cool.

Do not use this grill unless all parts are in place. This grill must be properly assembled according to the assembly instructions. Improper assembly may be dangerous.

Do not use this grill underneath any overhead combustible construction such as cover porches, overhangs,

Exercise caution when operating your charcoal grill. It will be hot during cooking or cleaning, and should never be left unattended until the coals have cooled completely.

Do not move the grill during operation or afterward while the grill still contains hot coals or ash.

Keep children and pets away from the grill.

Do not use this grill within five feet of any combustible material. Combustible materials include, but are not limited to, wood or treated wood decks, patios, and porches.

Keep the grill on a secure, level surface at all times, clear of combustible material.

Do not use grill in high winds.



CALIFORNIA PROPOSITION 65 STATEMENT

WARNING: Combustion byproducts produced by this grill include carbon monoxide, a chemical known to the State of California to cause cancer, birth defects or other reproductive harm.



GENERAL TIPS & WARNINGS



Before you use your grill for the first time you must season the cooking grates with an initial burn-in. This process requires building and maintaining a fire for about 2 hours. See the next page for more info.

Do not use self-starting charcoal as it will give food an unnatural flavor.

Do not use lighter fluid, gasoline, kerosene, alcohol or other accelerant for lighting wood or charcoal. Use of any of these or similar products could cause a flare-up or explosion possibly leading to severe bodily injury.

Additional charcoal and/or smoking woods may be added while cook is in progress, but use caution. Always wear gloves and an apron when operating your El Dorado grill for safety.

After each use, coat the interior grates and bare metal with grapeseed oil while warm to reduce the chance of rust. Proper and regular seasoning will protect against rust and extend the life of your grill and cooking grates.

Paint is not warranted against rust and some exterior surfaces may require touch-up over time. Remove rust by sanding the area and touch-up with a high heat paint, available at most hardware stores.

OPERATING THE GRILL

PLACEMENT

Always position the grill securely on a flat, level surface (Fig 01) and safely away from flammable liquids and structures. At least 24" of clearance is recommended (Fig 02) from any combustible surface. Once in position, lock each of the two locking casters.

RAISING / LOWERING THE GRATES

The cooking grates are controlled by the cast-iron hand wheel and integrated auto-stop ratchet. To raise the grates upward (Fig 03), simply rotate the hand wheel toward you and allow the ratcheted stop positions to secure the grates at the height you choose. To lower the grates (Fig 04), grasp the hand wheel with left hand while releasing the ratchet handle with right hand. **NOTE: Failing to grasp the hand wheel while lowering grates could cause them to lower too quickly and cause injury.**

FIREBOX DOOR ACCESS

The door at the front of the firebox can be opened by first lifting (Fig 05) then pulling the door handle toward you, allowing easy access to the firebox as needed for adding wood or charcoal, as well as raking ash into the cleanout vents (Fig 06).

ASH REMOVAL

Removing ash and debris from the grill's firebox is safe and simple. First, open the firebox access door and use the included ash rake to draw the ash/cooking debris into the clean out vents located towards you near the door (Fig 05). Close the firebox door and proceed to open/empty each ash drawer by lifting the small retention lock (Fig 07) allowing the drawer(s) to slide open (Fig 08). **NOTE: DO NOT empty hot ash or coals until completely cooled to avoid injury.**

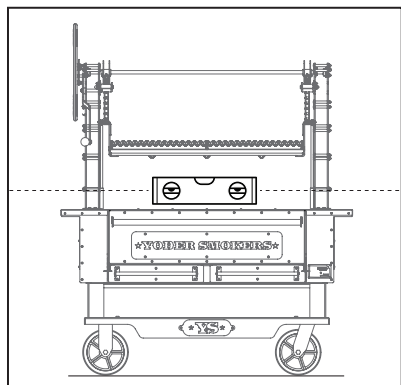

FIG 01 SECURE ON A FLAT, LEVEL SURFACE

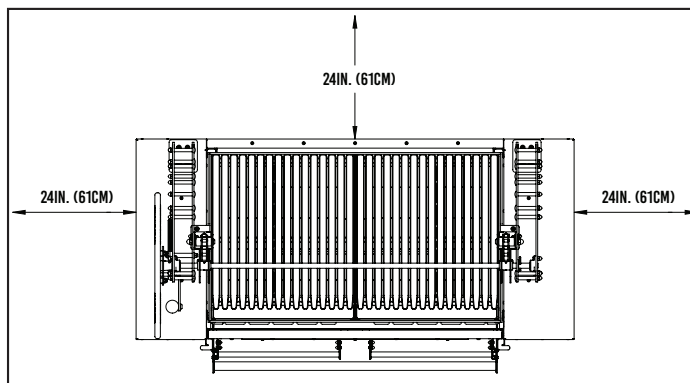

FIG 02 POSITIONING WITH SAFE CLEARANCE AROUND THE GRILL

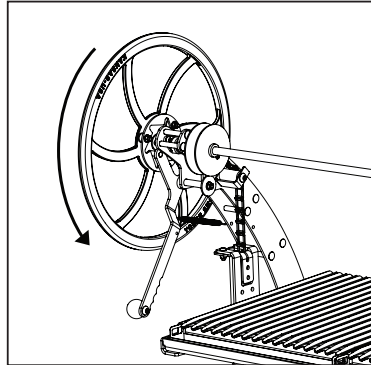

FIG 03 RAISING COOKING GRATES

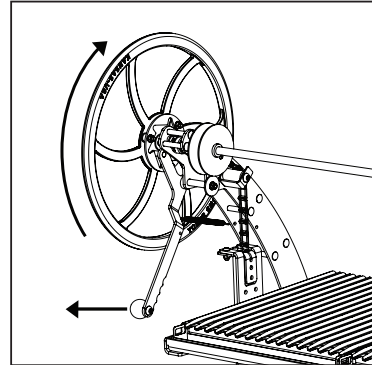

FIG 04 LOWERING COOKING GRATES

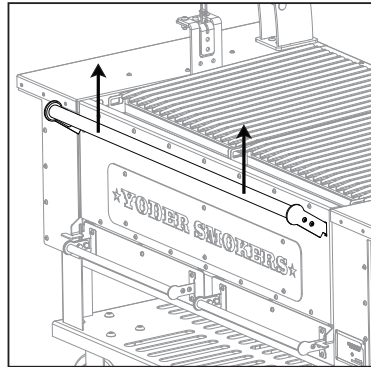

FIG 05 ACCESSING THE FIREBOX
ASH CLEANOUT VENTS

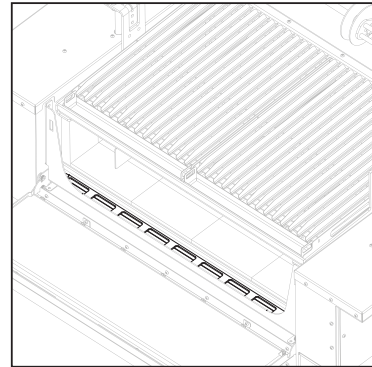

FIG 06 ACCESSING THE FIREBOX
ASH CLEANOUT VENTS

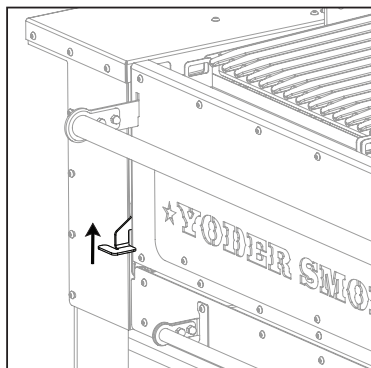

FIG 07 ACCESSING THE ASH
CLEANOUT DRAWER

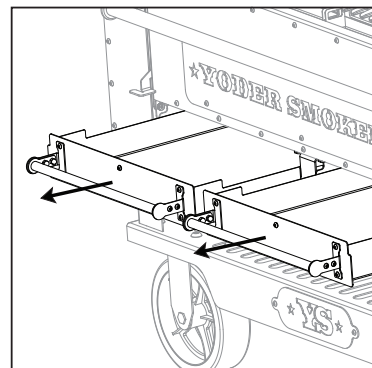

FIG 08 ACCESSING THE ASH
CLEANOUT DRAWER

THE INITIAL BURN-IN

STEP 01

Raise the grates to the middle position. Coat the entire surface of the cooking grates from bottom to top with Grapeseed oil. Make sure to apply the oil into all the grooves and grate surfaces. Grapeseed oil has a high heat / low smoke point property excellent for high heat style cooking. This oil goes on thick and not only protects and maintains the grate's integrity, but assures grilling success and results. Other high heat oils will also work such as Avocado oil and Flax Seed oil.

STEP 02

Once the grates have been oiled, leave them in the raised middle position. Add four to five pounds of charcoal off to one side of the firebox floor. We recommend using a charcoal chimney for easy lighting. (This style of cooker lends itself to the use of lump charcoal.)

STEP 03

As the charcoal begins to build a coal bed, take the ash rake and spread the hot coals across the entire firebox. Allow this to burn for 30-45 minutes. You can also add a couple pieces of split wood to produce some additional smoke and heat production if the wood is available.

STEP 04

Allow the cooking grates to become searing hot (test this by dripping a little water onto the grates and if they are ready the water will vaporize immediately). At this point you will apply another round of oil to the cooking grates using a 100% terry cloth towel, otherwise known as a "bar mop". Grip the towel with a set of tongs to keep your hands safe from burns, apply the oil to the towel, and simply push the towel along the grates to evenly coat them with the oil.

STEP 05

Finally, allow the fire/coals to season the grates for at least an hour or until the coals burn out. Once this is complete the cooking grates are seasoned and you are ready to cook.

YOU SHOULD KNOW

This is a very important step with any new grill. This process will burn away any residual debris, oils or potentially harmful impurities from the manufacturing process as well as properly prepare your cooking grates for a non-stick grilling surface. We very highly recommend burning-in your new El Dorado grill for an optimal and safe grilling experience.

COOKING ON THE GRILL

LIGHTING THE GRILL

Fill a chimney starter with lump charcoal and ignite. A chimney starter is not required but this method is the simplest and quickest way to get your charcoal burning. In about 15 minutes or once the coals begin to ash, dump them into the firebox of your grill.

FIRE MANAGEMENT

Now that your charcoal has formed a coal bed, you can also add 2-3 wood splits to the coals. Keeping your fire hot in an open pit relies on maintaining your fuel, so as the fuel burns down every 30-40 minutes add additional fuel to the coal bed. **NOTE: Remember that adding wood to the grill will spike the temperature, so make any necessary grate height adjustments accordingly.**

TEMPERATURE CONTROL

The key to controlling the temperature revolves around the grill grate position and its proximity to the coals/fire. That said, when you want to increase the heat to the grates, lower them downward for a closer proximity to the coals. Inversely, when you want to ease up on the intensity of the heat, raise the grates upward and away from the coals.

DIRECT GRILLING

The process of direct grilling involves cooking over direct heat, preferably over a hot coal bed or over direct flames that are low and under control. This method of grilling is ideal for cooking burgers, wings, chicken breasts, vegetables, and of course searing steaks. When direct grilling build your coal bed/fire central to the fire box to allow the most uninterrupted heat to the grates. Take care to adjust the grates carefully to prevent burning as direct grilling means quicker, more intense heat.

INDIRECT GRILLING

The process of indirect grilling, or offset grilling, involves cooking in proximity to the coal bed/fire. Indirect grilling is ideal for those foods that require less intense exposure to the heat such as fish, chicken and ribs, or any foods that require time to cook slower at a lower temperature. When indirect grilling build your coal bed/fire off to one side of the fire box (or along each side of the fire box).

MULTI-ZONE GRILLING

For a combination of grilling temps, a multi-zone environment can be created with an intense fire on the right side furthest away from the hand wheel, a moderate fire in the middle and no fire at all on the left side of the fire box. This environment allows for multiple temperatures at any given height of the fire, allowing you to cook different food simultaneously at different temperatures. It also allows you to move food around and change the temperature without having to adjust the grates.

MAINTENANCE & CLEANING

COOKING GRATES

At the end of each cook, and once you've removed your food from the grill, immediately oil the grates then lower them all the way down to burn off any food that's been baked onto the grates. After about 30-45 minutes wipe down the grates with heavy-duty blue paper towels and then scrape off anything that is still left behind with a grill brush. We recommend a final coating of grape seed oil or avocado oil once the grates are clean.

GREASE MANAGEMENT

Visually inspect the fire brick and surrounding area for buildup, and scrape clean as needed.

SILICONE-PAINTED SURFACES

While most surfaces of the El Dorado are powder coated, the firebox is finished with high heat silicone paint. These surfaces should be regularly washed with mild soap and water to remove any grease, food oils, errant seasoning sprays or rubs as they are corrosive to the surface. Should any of these surfaces become compromised, they can easily be sanded and touched-up with high-heat paint found at home improvement stores.

In order to prevent such issues, we recommend treating these surfaces with a high-quality mineral oil or ACF-50, an Ultra Thin Fluid Compound (UTFC) that actively treats metal using advanced polar bonding technology. This application is recommended every six months to protect and maintain the integrity of the paint, as well as the endurance of the finish. Simply wash the exterior of the grill with mild soap and water and once dry, apply the oil. Allow 15 minutes for absorption into the paint then wipe away any excess.

CHAIN DRIVE

Every six months we recommend treating the chain drive with a quality bar-and-chain oil to help protect the endurance of the black-oxide coating and maintain optimal performance.

FREQUENTLY ASKED QUESTIONS

QUESTION	ANSWER
CAN I USE LIGHTER FLUID TO LIGHT MY GRILL?	We recommend using a charcoal chimney for ease of use. While you can use lighter fluid to start your fire, it could negatively impact the taste of your food.
DO I HAVE TO USE CHARCOAL?	No. You can build your heat source with wood splits. One they burn down the wood creates a coal bed similar to charcoal.
WHY DO MY GRATES LOOK SO DARK?	As you cook more on the grill, the grates will achieve a natural patina. This is completely normal and part of the process, and helps to create a non-stick surface on the grates.
CAN I ADD FOOD TO MY GRILL WHILE THE FIRE IS GETTING STARTED?	We recommend waiting until your fire is producing coals and the “dirty” smoke is no longer visible.
WHAT HAPPENS IF MY FIRE GETS TOO HOT FOR THE FOOD I HAVE COOKING?	Simply raise the grates upward with the hand wheel.
CAN I MOVE MY GRILL WHILE COOKING?	Moving the grill while in use or immediately after use can be dangerous. We recommend committing to a location while cooking and not moving the grill until completely cool.
HOW LONG AFTER COOKING CAN I LEAVE MY GRILL SAFELY UNATTENDED?	The grill may take 2 hours or more to cool completely. DO NOT leave the grill unattended prior to cooling.
HOW DO I SET UP THE GRILL FOR DIRECT COOKING?	Build your fire/coal bed central to the grate you are going to use. If you want to use the entire surface, build your fire central to the grates . See more on pg.11
HOW DO I SET UP THE GRILL FOR INDIRECT COOKING?	Build your fire/coal bed opposite the grate that you intend to cook on. See more on pg.11

EL DORADO 42" FIREBOX COMPONENTS

ITEM #	PART #	DESCRIPTION	QTY.
1	W411010	YS, WELDMENT, EL DORADO, FIREBOX, 42	1
2	W410804	YS, WELDMENT, EL DORADO, SIDE PANEL	2
3	W411298	YS, WELDMENT, EL DORADO, GUIDE ROD TUBE	2
4	W411362	YS, WELDMENT, ASH RAKE, 24", FLAT	1
5	205584	4.5X9X1.25 FIREBRICK	41
6	205584-101	4.5X4-7/16X1.25 FIREBRICK (HALF CUT)	1
7	205587	SCREW, SHOULDER, SOCKET HEAD, 3/8X5/16, 1/4-20, 18-8SS	4
8	22860	TAG, SERIAL NUMBER, YODER SMOKERS	1
9	236-2489-02	RIVET, POP, 1/8 DIA. X 3/8 GRIP	4
10	410695-101	YS, EL DORADO, BRICK RETAINER, RH SIDE	1
11	410695-102	YS, EL DORADO, BRICK RETAINER, LH SIDE	1
12	410805	YS, EL DORADO, SIDE ACCESS COVER	2
13	410841-101	YS, EL DORADO, ASH DRAWER, CATCH, RIGHT	1
14	410841-102	YS, EL DORADO, ASH DRAWER, CATCH, LEFT	1
15	411026-101	YS, EL DORADO, SHELF COVER, SS, RIGHT	1
16	411026-102	YS, EL DORADO, SHELF COVER, SS, LEFT	1
17	411027	YS, EL DORADO, 42, REAR TRIM AND BRICK RETAINER, STAINLESS	1
18	411354	YS, EL DORADO, 42, BRICK TRIM, FRONT	1
19	411355	YS, EL DORADO, BRICK TRIM, CORNER	2
20	1420FHNSS	HEX, NUT, FLANGE, 1/4-20, STAINLESS	40
21	1420X12BHCSSS	SCREW, CAP, BUTTON HEAD, 1/4-20 x 1/2", STAINLESS	13
22	1420X58BHCSSS	SCREW, CAP, BUTTON HEAD, 1/4-20 x 5/8", STAINLESS	57

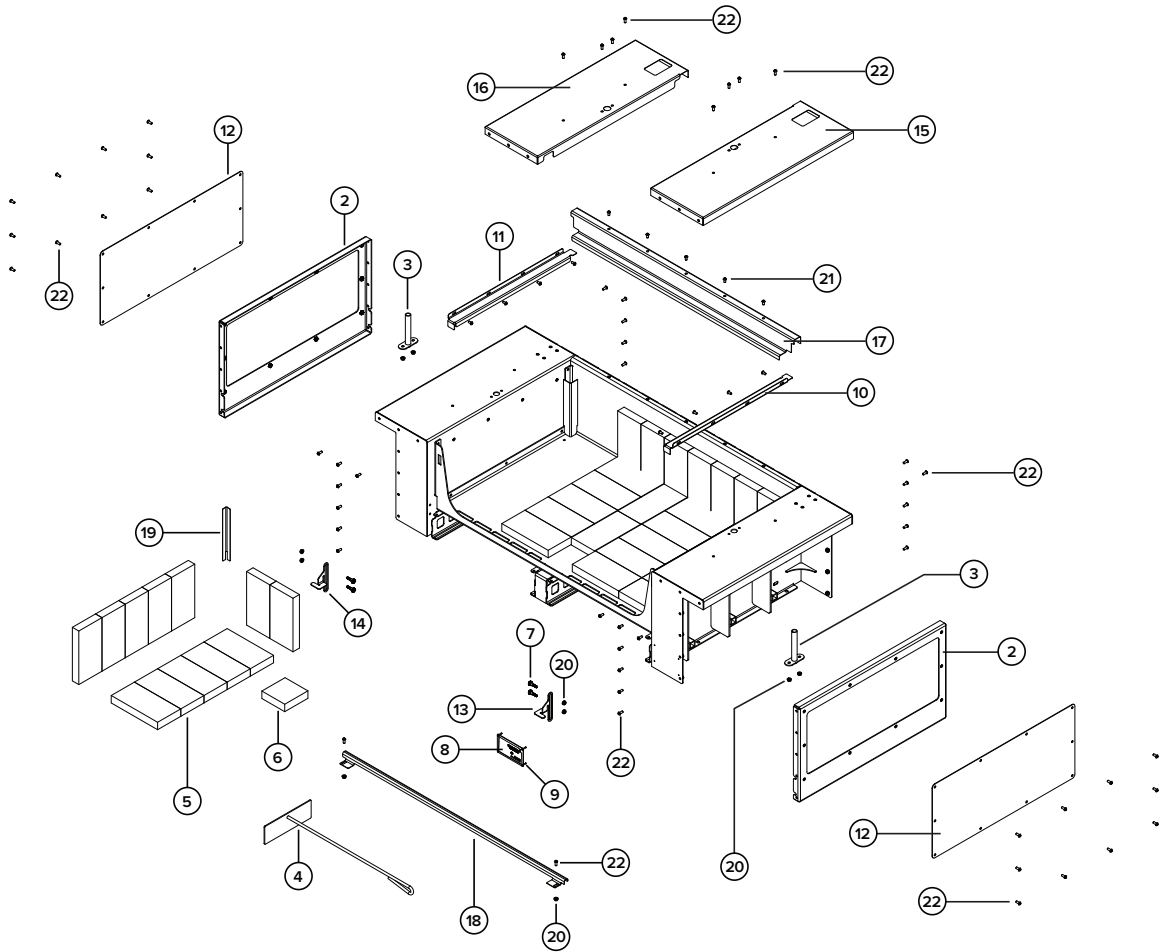

EL DORADO 42" COOKING COMPONENTS

ITEM #	PART #	DESCRIPTION	QTY.
1	411025	YS, EL DORADO, GREASE CATCH, SS, FOR 42" MODEL	2
2	W411015	YS, WELDMENT, EL DORADO, V-GRATE, SS, FOR 42" MODEL	2

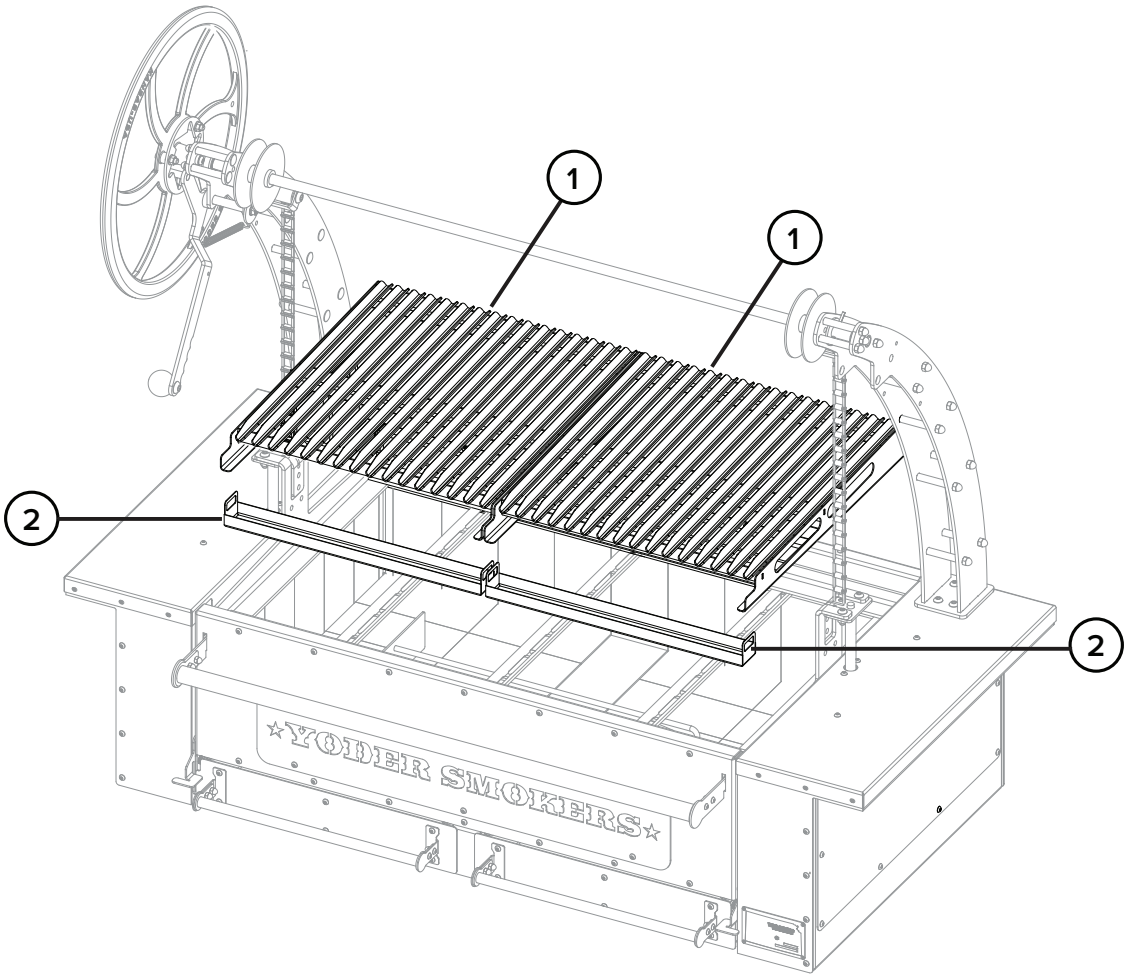

EL DORADO 42" LIFT ASSEMBLY COMPONENTS

ITEM #	PART #	DESCRIPTION	QTY.
1	W411013	YS, WELDMENT, EL DORADO, LIFT, 42	1
2	W411200	YS, WELDMENT, EL DORADO, GUIDE ROD	2
3	3816FHNS	NUT, HEX, FLANGE, 3/8-16, STAINLESS	5
4	3816X1BHCSS	SCREW, CAP, BUTTON HEAD, 3/8-16 x 1", STAINLESS	4
5	701-212-02	COTTER, HAIRPIN, 1/8 DIA X 2-3/8, 1/2 TO 5/8 PIN	2
6	12FW	WASHER, FLAT, 1/2"	2

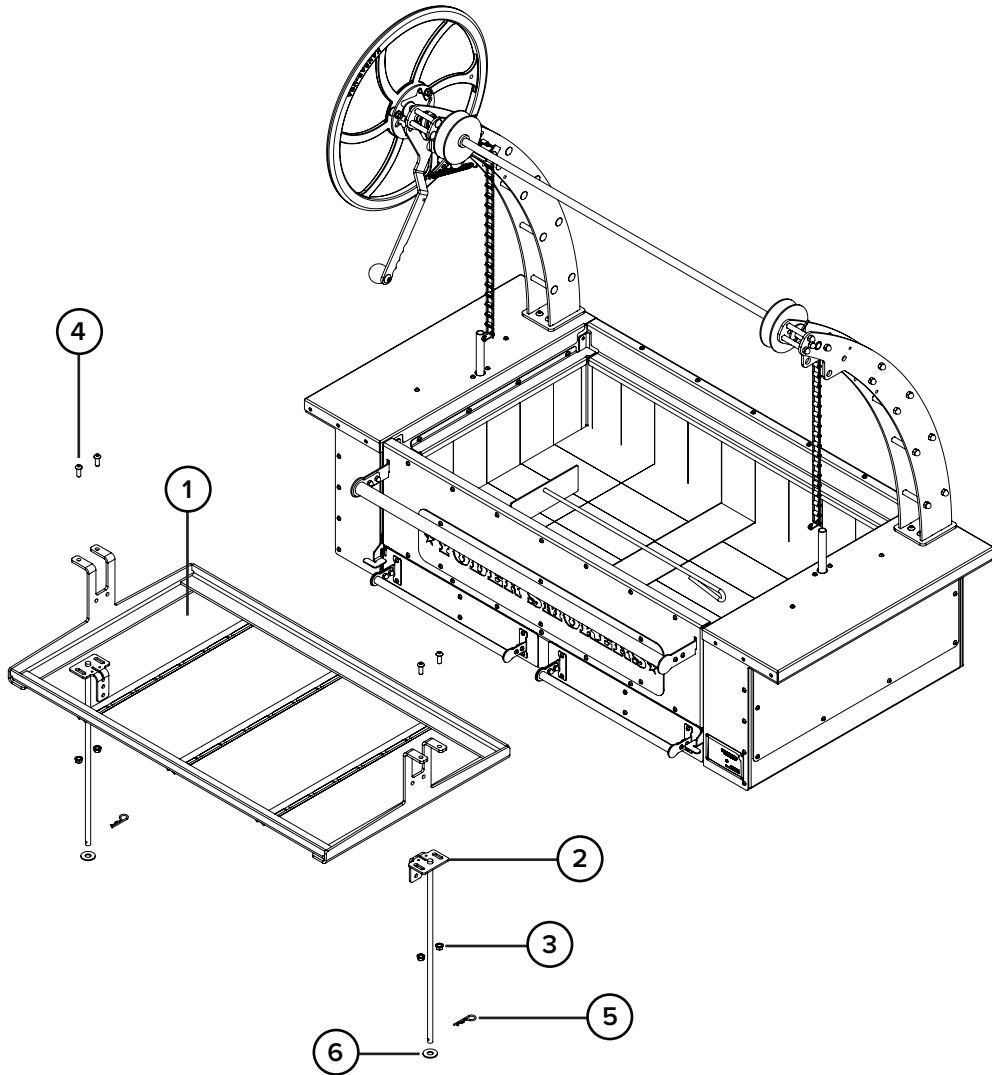

EL DORADO 42" LIFT CHAINS COMPONENTS

ITEM #	PART #	DESCRIPTION	QTY.
1	205695	STEEL DETACHABLE CHAIN LINK, 32W	46
2	3816X112BHCSSS	SCREW, CAP, BUTTON HEAD, 3/8-16 x 1½", STAINLESS	8
3	410696	YS, EL DORADO, CHAIN RETAINER	2
4	832HN	NUT, HEX, 8-32	4
5	832X12BHCSSS	SCREW, CAP, BUTTON HEAD, 8-32 x 1/2", SS	4

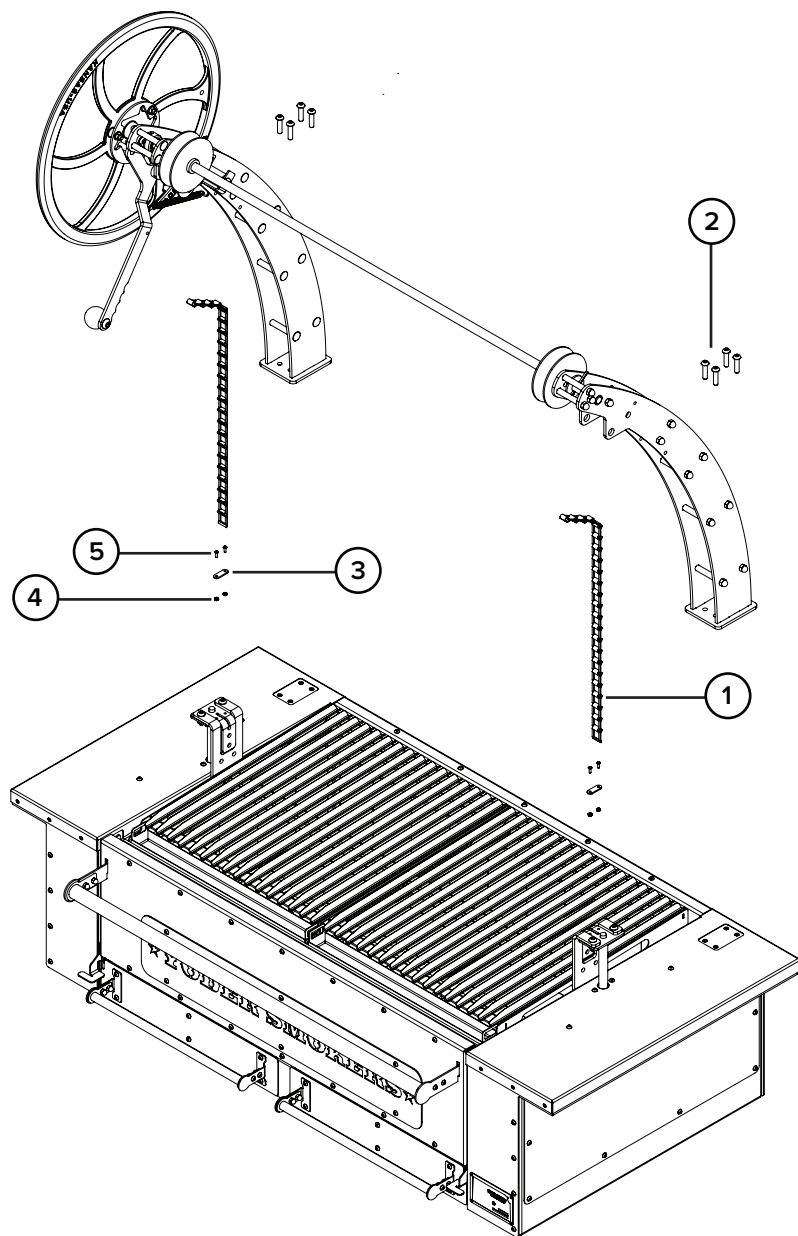

EL DORADO 42" UPPER ASSEMBLY COMPONENTS

ITEM #	PART #	DESCRIPTION	QTY.
1	A411174	YS,ASSY, EL DORADO, WHEEL, REMOVABLE RATCHET	1
2	A411189-101	YS, ASSY, EL DORADO, CANTILEVER LIFT ARM, FOR ALL SIZES	1
3	A411189-102	YS, ASSY, EL DORADO, CANTILEVER LIFT ARM, FOR ALL SIZES	1
4	A411198	YS,ASSY, EL DORADO, RATCHET ARM, SHEETMETAL, STEEL KNOB, LH	1
5	W410993	YS, WELDMENT, EL DORADO, CHAIN GUIDE	2
6	205582	BEARING, DRY-RUNNING, SLEEVE, 2-BOLT MOUNT, FOR 3/4" SHAFT, 2820T38	2
7	205660	SPRING, STAINLESS, 0.5OD, .063 WIRE, HOOK ENDS	1
8	205696	SPRING PIN, SLOTTED, 1/4" X 1.25", STAINLESS	3
9	205697	S-HOOK, 1", OPEN END, STAINLESS	2
10	23548	PIN, COTTER, 3/16 x 2"	1
11	411033	YS, EL DORADO, 42, LIFT, ROTARY SHAFT, 0.75" DIA	1
12	411101	YS, EL DORADO, LIFT HANDLE, SPACER	1
13	411178	YS, EL DORADO, CHAIN IDLER TUBE	2
14	411182	YS, EL DORADO, IDLER BRACKET	2
15	411283	YS, EL DORADO, IDLER, ROLLER	2
16	1420FHNSS	HEX, NUT, FLANGE, 1/4-20, STAINLESS	2
17	1420X134BHCSSS	SCREW, CAP, BUTTON HEAD, 1/4-20 x 1-3/4", STAINLESS	2
18	1420X58BHCSSS	SCREW, CAP, BUTTON HEAD, 1/4-20 x 5/8", STAINLESS	2
19	14FWSS	WASHER, FLAT, 1/4" SS	2
20	14HNSSA	NUT, HEX, ACORN, STAINLESS, 1/4-20	2
21	3816FHNSS	NUT, HEX, FLANGE, 3/8-16, STAINLESS	1
22	3816LNN	NUT, HEX, NYLOCK, 3/8-16, GR5, ZN	8
23	3816X112BHCSSS	SCREW, CAP, BUTTON HEAD, 3/8-16 x 1 1/2", STAINLESS	8
24	3816X34BHCSSS	SCREW, CAP, BUTTON HEAD, 3/8-16 x 3/4", STAINLESS	4
25	3816x45BHCSSS	SCREW, CAP, BUTTON HEAD, 3/8-16 x 4.5", STAINLESS	1
26	38FW	WASHER, FLAT, 3/8"	8
27	38FWSSSAE	WASHER, FLAT, 3/8" SS	1
28	38HNSSA	NUT, HEX, ACORN, STAINLESS, 3/8-16	4
29	1213X312BHCSSS	SCREW, CAP, BUTTON HEAD, 1/2-13 x 3.5", STAINLESS	2
30	12HNSSA	NUT, HEX, ACORN, STAINLESS, 1/2-13	2
31	34FW	WASHER, FLAT, 3/4"	2

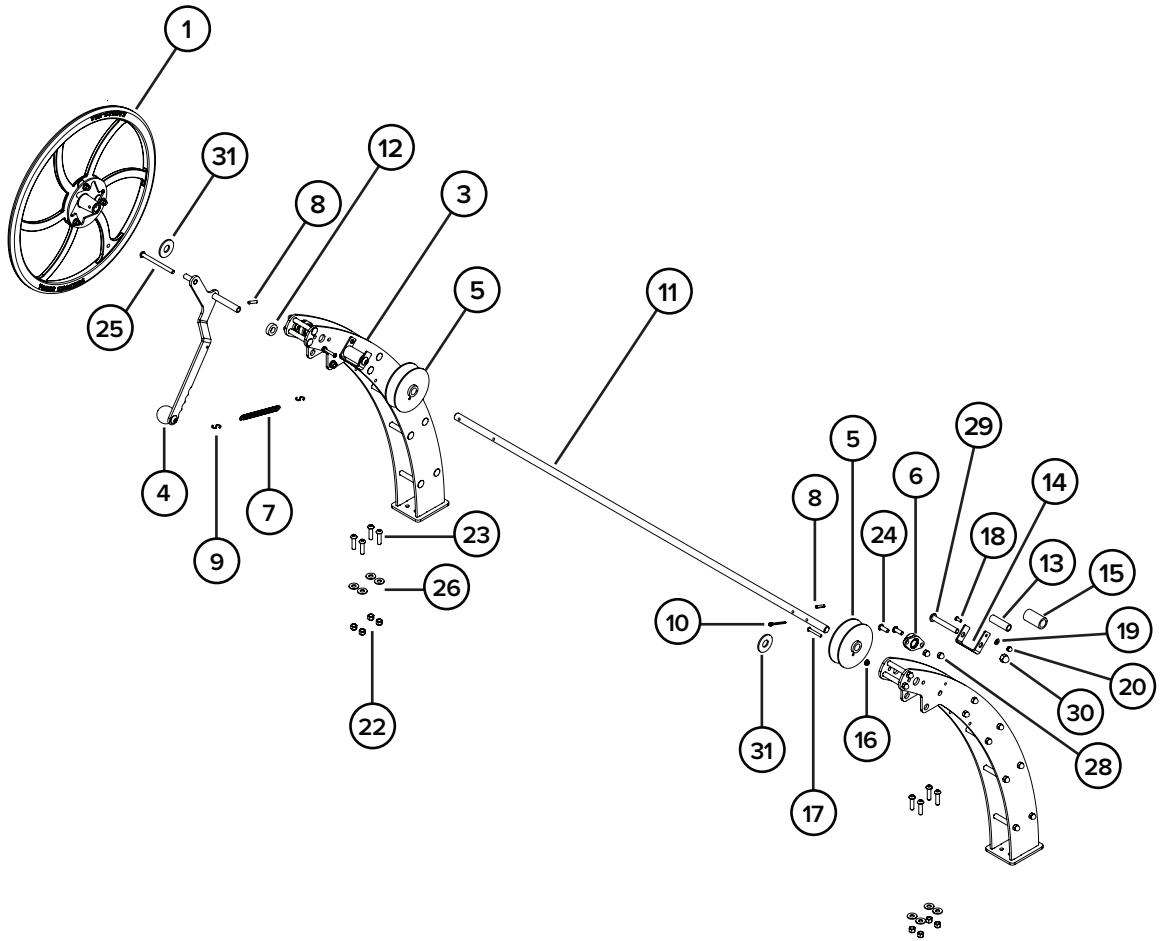

EL DORADO 42" CART COMPONENTS

ITEM #	PART #	DESCRIPTION	QTY.
1	W411191	YS, WELDMENT, EL DORADO, CART BODY, 42	1
2	205574	10IN, RIGID CASTER	2
3	205575	10IN, SWIVEL CASTER	2
4	410785	YS, EL DORADO, CART, SIGN	2
5	1420LNN	NUT, HEX, NYLOCK, 1/4-20, ZINC	4
6	1420X58BHCSSS	SCREW, CAP, BUTTON HEAD, 1/4-20 x 5/8", STAINLESS	4
7	1213LNN	NUT, HEX, NYLOCK, 1/2-13	16
8	1213X114BHCSSS	SCREW, CAP, BUTTON HEAD, 1/2-13 x 1-1/4", STAINLESS	16

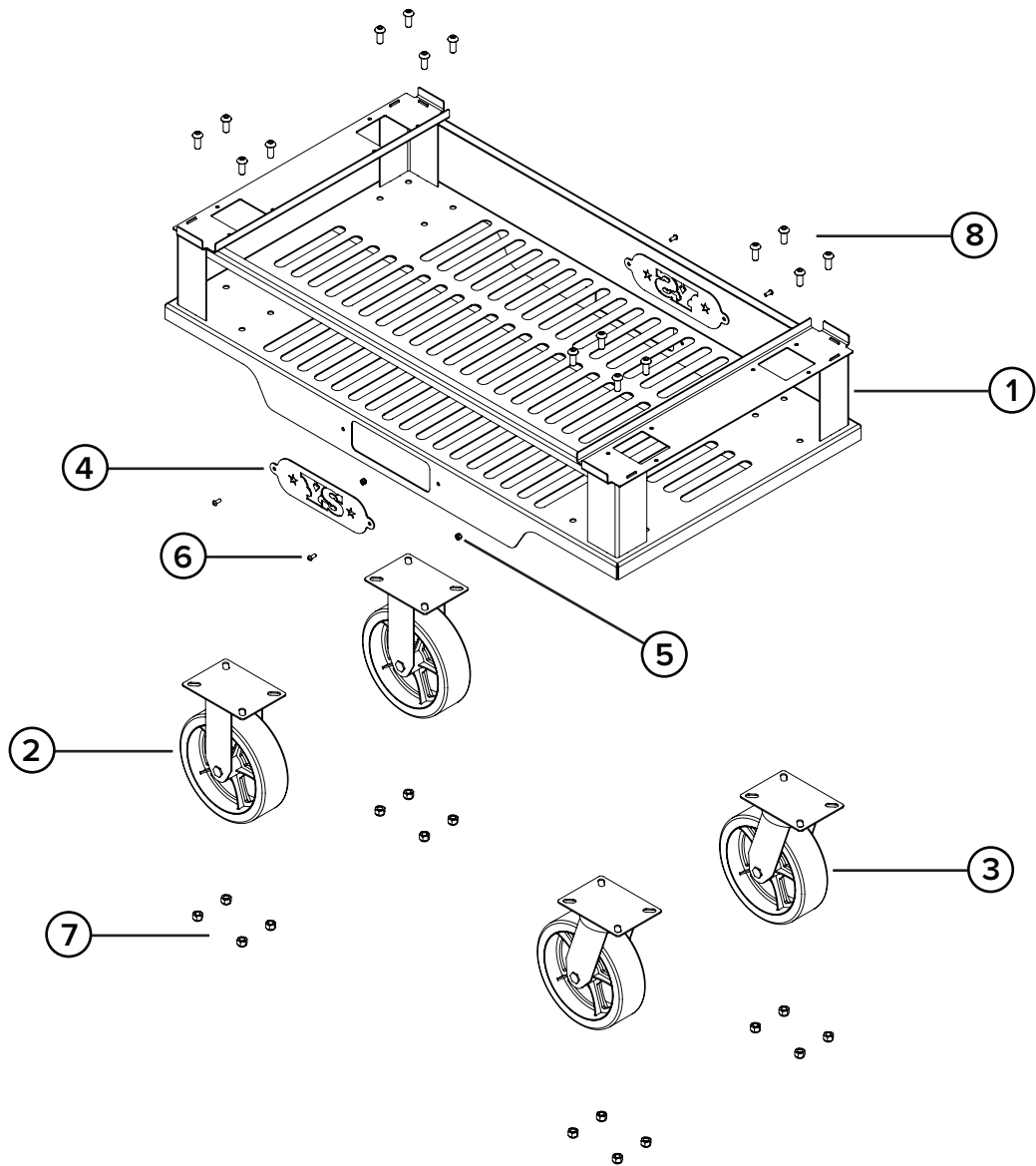

THE YODER SMOKERS LIMITED WARRANTY

The Yoder Smokers El Dorado grill is guaranteed to be free from defects in material and workmanship when utilized for residential, non-commercial use, and when the grill has been set up, cleaned, and maintained in accordance with factory recommendations. This Limited Warranty covers parts deemed defective by Yoder Smokers, Inc. (the “Company”) only, and does not cover any labor costs for diagnosis, troubleshooting, removal, installation, export duties, or shipping, freight, or other transportation to or from the Company.

The Yoder Smoker cooker must be registered with the Company within 30 days of purchase for the warranty to be valid. Whether you register electronically or by mail, you should retain the sales receipt and other proof of original purchase, as this may be required for claims under this Limited Warranty. Please register electronically here: yodersmokers.com/warranty-registration-form.

THIS LIMITED WARRANTY COVERAGE INCLUDES:

The main cooking chamber is warrantied against burn through for ten years from the original purchase date.

All other components not specifically listed above, are warrantied for six months from the manufactured date of the Yoder Smoker, or from the original purchase date, with proof of purchase.

Any warranty replacement component is warrantied for one year from the date of shipment. This would be any component that has been replaced after the original warranty period has expired.

REGISTER YOUR GRILL:

www.yodersmokers.com/warranty-registration-form/ or call 877-409-6337 Option 2.

The Company's sole obligation under this Limited Warranty shall be to repair or replace, at its option, any part deemed defective upon examination by the Company, upon claims received by the Company during the specific warranty periods outlined above. The customer must obtain approval from the Company before performing any service or repair by submitting a warranty claim under this Limited Warranty. The Company is not obligated under this Limited Warranty following any unauthorized service or repair work and is not responsible for the charges of any repairs beyond repair or replacement, at its option, of covered warranty claims. Repair or replacement of any parts will not extend the original warranty coverage.

- This Limited Warranty is transferable for the duration of the specific warranty periods outlined above.
- To make a warranty claim under this Limited Warranty, the owner must notify the Company for troubleshooting, and subsequent instructions, as to service and replacement of defective part(s) before attempting repair of the Yoder Smoker.
- The model number, serial number, and manufacturer date of the Yoder Smoker must accompany any warranty request. For warranty claims made outside the warranty periods commence previously submitted to the Company.
- This Limited Warranty does not apply to damage caused by abuse or use of the product for purposes other than that for which it is designed. If damage is caused by lack of proper use, assembly, cleaning, maintenance, installation, accidents, natural disasters, by unauthorized third party attachments and/or modifications, by unauthorized service, or during shipment, this Limited Warranty is not applicable.
- The Limited Warranty is void on any Yoder Smoker being used in any commercial or food service setting (including but not limited to restaurant or catering use).
- This Limited Warranty does not cover damage from normal wear and tear from use of the Yoder Smoker (for example, scratches, dents, dings, and chipping) or changes in the appearance of the Yoder Smoker that do not affect its performance.
- This Yoder Smoker must be operated, cleaned, and maintained at all times in accordance with the instructions in the Owner's Manual. This Limited Warranty will not apply if your product has not been assembled, operated, cleaned, and maintained in strict accordance with the manufacturer's instructions, or placed in accordance with minimum clearances as listed in the Owner's Manual.
- A copy of the Owner's Manual may be found online at <https://www.yodersmokers.com>.
- Performance problems due to operator error will not be covered by the Limited Warranty.
- As this is a grill/cooker, the interior may experience changes in the color of the surface finish. This is not a flaw and as such is not covered under this Limited Warranty.
- Burning anything other than premium food grade pellets as fuel for the Yoder Smoker shall void this Limited Warranty.
- There is no written or implied performance warranty on any Yoder Smoker, as the manufacturer has no control over the assembly, operation, cleaning, and maintenance or the type of fuel burned.
- High ambient temperatures, excessive humidity, chlorine, industrial fumes, fertilizers, lawn pesticides, acid, and salt are some of the substances that can affect metal coatings. For these reasons, the Limited Warranty DOES NOT COVER PAINT, RUST OR OXIDATION, unless there is a loss of structural integrity on the cooker's components during the specific warranty coverage period.
- The Company will not be responsible for performance issues caused by environmental conditions.
- The Company will not be responsible for performance issues caused by electrical power.
- Damage to painted surfaces caused by scratches, melted items, drips/spills, external scores, and residues left on these surfaces from the use of marinades, seasonings, oils, brines, abrasive cleaners, polishes, or other BBQ products is not covered in this Limited Warranty.
- Any modifications including holes, screws, and any other sheet metal changes to the product will void this Limited Warranty.
- You are responsible for any costs of shipping related to claims under this Limited Warranty. Original parts required by the Company to be returned must be returned prepaid.

There are no express warranties other than the limited warranties stated herein above. No warranties whether express or implied, including, but not limited to, any implied warranties of merchantability of fitness for a particular purpose shall extend beyond the respective warranty periods described above.

The Company shall not be liable for any direct, indirect, special, consequential, incidental, or punitive damages; lost profits or loss of use or interruption of business regardless of the form of action or theory of liability resulting from any defect in, or use of, any Yoder Smoker, accessories and/or heating elements. In no event shall the Company's obligations exceed the purchase price of the unit. This Limited Warranty gives the customer specific legal rights and the customer may have other rights which vary from state to state. In consideration of this Limited Warranty, the customer agrees that any dispute related to any Yoder Smoker, or this Limited Warranty, shall be conducted in Reno County, Kansas and subject to Kansas law.

THIS LIMITED WARRANTY GIVES YOU SPECIFIC RIGHTS WHICH MAY VARY FROM STATE TO STATE. THE LIMITED WARRANTY IS IN LIEU OF ALL OTHER WARRANTIES, STATUTORY OR OTHERWISE, EXPRESS OR IMPLIED, ALL OTHER REPRESENTATIONS MADE BY THE COMPANY OR ANY THIRD PARTY DISTRIBUTOR OR RETAILER AND ALL OTHER OBLIGATIONS OR LIABILITIES WITH RESPECT TO THE UNIT COVERED BY THIS LIMITED WARRANTY WHICH, AT THE TIME OF PURCHASE OR AT ANY TIME IN THE FUTURE, MAY BE MADE AGAINST THE COMPANY, ITS OFFICERS, DIRECTORS, EMPLOYEES, AND AGENTS. EXCEPT as expressly provided herein, THE COMPANY gives no other express or implied warranties relating to fitness for USE OF THE UNIT; merchantability of the UNIT, fitness for a particular purpose of the UNIT, quality of the UNIT; or condition of the UNIT. THE COMPANY'S obligations shall not exceed its obligation expressly set forth in THIS LIMITED WARRANTY.

For warranty claims, please verify you have registered your cooker within 30 days of purchase to validate your warranty. Contact Yoder Smokers Customer Service via email at customerservice@yodersmokers.com or by calling 877.409.6337, option 2, and include the model of your cooker, the serial number, the build date, your name, shipping address and contact phone number, and a detailed description of the issue or problem.

**MADE**TM
HANDCRAFTED IN THE USA



FOR PRODUCT SUPPORT CONTACT

CustomerService@YoderSmokers.com

877.409.6337 (OPTION 2)

★ YODER SMOKERS ★

PREMIUM GRILLS & SMOKERS

1816 E WASP RD. | HUTCHINSON, KS 67501 | 877.409.6337

YODERSMOKERS.COM

VERSION 10.2024